

TUFF-DECK
MODULAR ELECTRONIC VEHICLE SCALES

ACTIVE
SCALE
MANUFACTURING INC

CONCRETE TUFF-DECK
SIDERAIL VEHICLE SCALES



1 866-284-2223 • ACTIVESCALE.COM

TUFF-DECK

MODULAR ELECTRONIC VEHICLE SCALES

Load Cell Assembly

The standard Tuff-Deck utilizes a self restoring Rocker Pin design load cell, 30 tonne capacity each, with 150% safe working overload, and 350% ultimate overload capability.

This load cell is manufactured from 17-4 PH and 316 stainless steel materials and is highly resistant to corrosion. The latest manufacturing technologies are utilized in it's manufacture including laser welding. The load cells have factory matched outputs, requiring minimal field adjustments on initial and subsequent calibrations.

The Rocker Pin is purged and filled with inert gas, hermetically sealed to IP68

(submersion at 1 metre for 100 hours) and IP69K (high pressure steam jet) standards, is NTEP approved Class III L 10,000 d and OIML approved to R60 specifications.

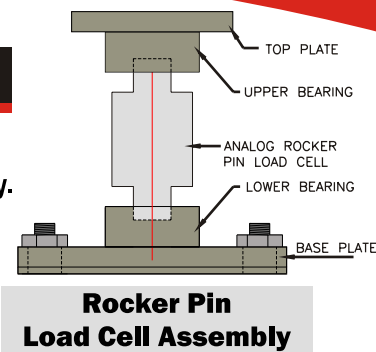

The signal cable from the load cells has internal braided shield to protect from R.F.I. There is a heavy duty external braid to provide mechanical protection from abrasion damage and chewing rodents.

The rocker pin load cell allows a simple mounting arrangement with one lower and one upper bearing. The load cell is supplied with a rubber boot to protect the lower bearing from mud contamination. There are no links or pins to wear out. The mount allows for high impact loading typical of highway vehicles and includes anti-rotation hardware. The rocker pin assembly compensates for thermal expansion of the weighbridge tolerating up to 5 degrees off-center loading.

Polycarbonate NEMA 4-X corrosion proof summation boxes with captive gasket system are mounted on the side of the scale to protect against moisture and condensation entry into the load cell signal summing system and includes a patented water proof vent system to prevent condensation forming in the summing boxes.

The Active Scale summing system is available with an optional remote section trimming kit located in the scale house allowing simple, fast initial and routine calibrations. The location of the remote calibration assembly in a controlled environment promotes the stability and accuracy of your scale and also provides faster calibration.

Weigh-Deck Options & Accesories

A complete line of accessories is available from digital weight indicators, printers and remote displays to bar code systems, computerized scale house ticketing systems and unattended weigh stations.

- Flat-deck Configuration
- X-tra Lo Profile
- Surge Protection
- Side Skirting
- Extended Warranties

Sizes and Capacities

- Widths
Standard Module Width is 10', Available 11', 12'. Custom Widths Availalbe to 16'.
- Lengths
Standard Module Lengths are 10', 15', 17'-6", & 22'-6". Custom Modules are Available to Suit Existing Foundations.
- Capacities
Standard Scale Capacities from 40 Tonnes to 100 Tonnes. Custom Scales available to 250 Tonnes.

Head Office & Plant

P. O. 2145, 6 York Road
Brantford, Ont., N3T 5Y6
Email: info@activescale.com

Toll Free: 1-866-284-2223
Fax : 519-756-0267
24 Hour Service: 1-800-850-8770

Products are available through Active Scale Sales Offices, or through dealers located across Canada and the United States

Specifications are subject to changes without prior notice

1 866-284-2223 • ACTIVESCALE.COM